

# Interaction Design Project Report

## R.A.G.E. – Recoiling Arcade Gun Experience

### Erik Einebrant

Computer Science and Engineering  
Chalmers University of Technology  
SE-412 96 Gothenburg, Sweden  
+46 738351442  
einebrant@hotmail.com

### Lin Lin

Computer Science and Engineering  
Chalmers University of Technology  
SE-412 96 Gothenburg, Sweden  
+46 737576183  
linlin.se@gmail.com

### Tobias Johansson

Computer Science and Engineering  
Chalmers University of Technology  
SE-412 96 Gothenburg, Sweden  
+46 707810206  
tobiasjohansson3000@gmail.com

### Mandis Söderström Johansson

Computer Science and Engineering  
Chalmers University of Technology  
SE-412 96 Gothenburg, Sweden  
+46 704137332  
mandis.sj@gmail.com

### ABSTRACT

In this paper we describe the process and outcome of our work developing a game and a game controller in shape of an arcade gun with physical recoil. During this project we have gained knowledge about how to work with electronics and also how to develop a game in the rail first person shooter genre.

### Keywords

Game development, interaction design, game controller.

### INTRODUCTION

R.A.G.E. stands for recoiling arcade gun experience and is the name of our project which aspired to create an arcade gun for home usage. (The project logotype is shown in figure 1). The goal was to enhance the user experience of playing computer games by creating a big, gun shaped game controller with physical recoil. We also wanted to create a game in the first person shooter genre, to play with the gun as the controller.

Very little of the project time was put on coming up with the original idea, as it was already formulated before the project started. Because of the same reason the given project theme, lightness, was worked around. In opposite the gun was to give a very heavy impression, this by its physical and visual appearance as well as in terms of interaction. Most of the project time was spent on experimenting and figuring out which technology to use for creating the recoil effect and how to implement it. We did also work with the visual design and usability of the gun. At the end of the project a prototype was displayed and user tested at an exhibition in the shopping mall Nordstan, where many casual testers got to try it out. This report describes the design process and realization of our concept, the

problems we encountered on the way and an evaluation of the final prototype.



Fig 1. R.A.G.E. project logotype.

### BACKGROUND AND RELATED WORK

In Rules of Play [1] the authors discuss games as activities from different perspectives, one of them being experience. They say that to play a game is to experience the game, and discuss what things the designer can do to create this experience for the player. The authors state that game designers do not design the play itself, but instead a “space of possibility”. This means that the designers set up the rules of the game world and provide ways for the player to

interact with it. The experience is created by the relations between input, output, and internal mechanisms of the game. When a game is created the design decisions should be taken depending on what experience the designer wants to create. In this project we wanted to enrich the experience by providing a controller specialized for first person shooter games. Our space of possibility is the game, with enemies approaching at the screen and the gun which the player has to use in order to defend herself against them.

The authors of Rules of Play also describe a model for how physiological processes create an experience for the user when playing a game. The five elements are visual scanning, auditory discriminations, motor responses, concentration and perceptual patterns of learning. Together these elements create the experience of a game. Motor responses are the physical actions the player takes with the game controller, and that is together with concentration, where the player feels like he is almost inside the game, what we have focused on during this project. The player sees what happens on the screen; if the enemies are approaching he aims at them with the gun and presses the button. As a response the controller gives the player recoil feedback to increase the experience by simulate that the gun actually has given fire.

The visual aspect of the project has always been treated as an important issue. In Emotional Design [2] Donald A. Norman refers to scientific discoveries that a beautiful design does not only appeal to the user's eye but actually makes the product generally better. Based on personal experience from arcade halls, we wanted the gun to be so physically appealing that it would be an active part of the related game. Smaller guns such as the Nintendo's Zapper or Sega's Virtua Gun (see figure 2) can easily be ignored once the game has started as they work much as extensions of the hand. The case is different with the larger guns which can be found in arcade halls. These guns are not only bigger but they also usually put physical demands on the user such that they may be locked to the arcade cabinet or that advanced motions are needed for some kinds of input.



**Fig. 2.** Nintendo Zapper to the left and Sega Virtua Gun to the right.

## CONCEPT

In the case of the R.A.G.E.-gun we wanted to provide a functional controller. It should be adapted for first person shooters by giving the player the possibility to aim at the enemies by simply pointing the gun at them, to shoot by pulling the trigger instead of pressing a button and give extensive feedback through physical recoil instead of just

providing a vibrating plastic game pad. This should require the user to concentrate on the interaction with the gun meaning that the physical interaction becomes more important. In opposite to the lightness theme of the project we wanted the controller to be very heavy. We thought this would represent a real gun better than a lightweight controller and if the gun became heavy enough, the player would get a sense of lightness when putting the gun down.

When it came to good looks of futuristic weaponry we chose to go for three aspects; non-trivial shapes, a clean design and details which makes sense. While using the base shape of the Pulse rifle from the Alien movies we wanted to look for more interesting and unusual shapes during the sketching (see figure 3).

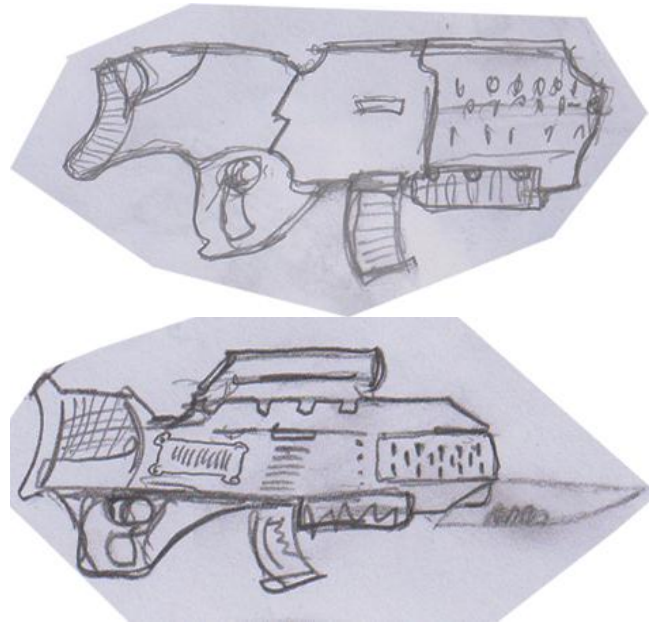

**Fig. 3.** Early concept sketches.

## REALISATION

### The Controller

#### Recoil

The most important thing in our project, which we also focused on, was the recoil. Since game controllers with real recoil for home usage do not exist, this was the part of the gun that would probably affect the user experience the most. Therefore we spent most of our time in the beginning of the project on figuring out how to build it. We had different ideas of how to realize this; door locks, power tool parts, super strong magnets etc. Since we could easily access it we decided to go with magnets and coils. (The first idea of realization is shown in figure 4).

We ordered some packages of magnets and got over a coil and a rod from a pinball machine. After some experimental sessions with a voltage cube we managed to get it working by putting the metal rod with magnets attached to it into the coil. By turning the power on and off the magnets were pushed in and out of the coil, which created a movement simulating real recoil.

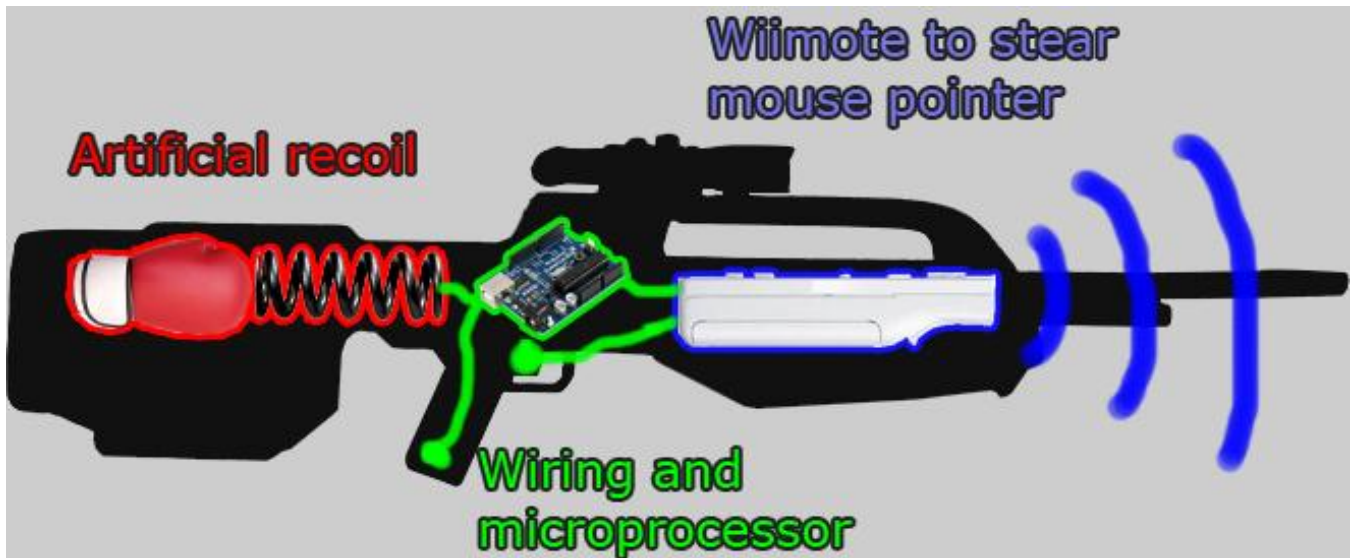

**Fig. 4.** Early sketch of the realization.

#### Prototype

We made the body of the gun by cutting the shape out of blocks of Styrofoam. This was a good choice as material since it was easy to work with and quick to shape as we wanted. We also had access to a lot of it in case the prototype would break. Some drawbacks were that hot glue caused it to melt and as we experienced later, it was a bit weak to stand the force of the recoil.

When the recoil was up and running we tried to put the construction into the prototype shell and the experience of recoil was pretty good. We noticed that the handle of the gun was a bit weak so we replaced it with one from a plastic toy gun instead. In this way we could also use the trigger of the toy gun as trigger for the controller by placing a button under it. Since the Styrofoam did not hold the recoil in place we built a plastic shell for the coil and rod that we put into the gun.

#### Wiimote Integration

Since we knew that Wiimotes work as pointing devices it was in our original idea to use one of those to be able to aim at the screen with the gun, we could also make use of the buttons as input to the game. We put the controller in the front of the gun, which felt like the most natural placements since it was the part closest to the screen. We took the controller apart, removed the upper shell and buttons so that we could solder wires directly onto the connection surfaces (see figure 5). Then we connected the trigger to two of the surfaces, the ones under the A button, so that the circuit would be closed when the trigger was pulled. The Wiimote was then giving a signal that the A button was pressed when the trigger was pulled. We also soldered cables to the synchronize button so that we could use an external button to synchronize it with the computer since the original buttons were hard to reach when the Wiimote was inside the gun.



**Fig. 5.** Wires soldered onto the Wiimote.

## Electronics

To activate the recoil when the trigger was pulled and to get the parts to communicate with each other we of course had to work with electronics too. To coordinate everything we used an Arduino which is connected to the trigger, a temperature sensor, transistors for the coil and cooling fans and a nine volt battery. While the trigger is pressed, the Arduino receives a continuous input signal. The Arduino then gives an output to the transistor circuit for the coil, turning it on and off ten times a second. When it receives the Arduino signal, the transistor lets the high voltage from the external power supply through to the coil, which makes the rod with the magnets moving back and forth.

The temperature sensor is connected as an input to the Arduino, which is programmed to stop the output to the coil transistor if the temperature rises too much. The Arduino also sends an output to the transistor for the fans if the temperature gets close to the threshold, which then lets the power from a nine volt battery through to start the fans. (For circuit diagram see figure 6).

## The Game

We developed the game in Visual Studio using the XNA Gamestudio framework, which is a good and accessible tool for making games. The game consists of a short level where the player moves in a 3D- world with monsters showing up now and then. The players' mission is to shoot the enemies before they reach him or her, if not the player is sent back to the beginning of the level. During our work we have implemented a first person camera, programmed the movement of the monsters so that they are going towards the player and methods for determining whether the players shots hit any of the game objects. The players' movement in the game world is controlled automatically, since there is no way to steer with our controller.

We use a script to control what happens in the game world, the movement of the player and where the enemies will spawn. The text in the script is parsed as input to the update methods of the games, which provides an easy way writing levels.

To make it possible to control the game with the Wiimote, an external library for C# called Wiimotlib was used. We integrated this into the game project, since it was more flexible than running an extra program that makes it possible to control the mouse cursor with the Wiimote. In this way we could take the input from the other buttons of the Wiimote as well, otherwise pressing a button on the Wiimote would have been interpreted as a mouse click. When the player is pointing the gun at the screen the game calculates the position on the screen where the Wiimote is pointing and draws the crosshair at that position. If the trigger is pulled, the game calculates if there is an enemy in that position. If there is, that enemy is hit.

## Final Iterations

The exhibition week at Nordstan was the first actual stress test of the gun. From the development period we were aware of some issues that made the gun dysfunctional until fixed. The spring in the recoil broke after some time of shooting, the coil got very hot and would eventually break if it was not cooled and the trigger button would not give a signal if pressed as hard as it could be. Because of these problems we had brought a wide range of tools and some spare parts for repairs in a first aid kit to Nordstan. As the exhibition proceeded we experienced new weaknesses in the construction of the gun such that the heat would melt the glue which held the components in place a main, and that the spring broke faster the less linear its movement was. The first days we repeatedly had to cool the coil with compressed air and replace the spring to keep the controller running.

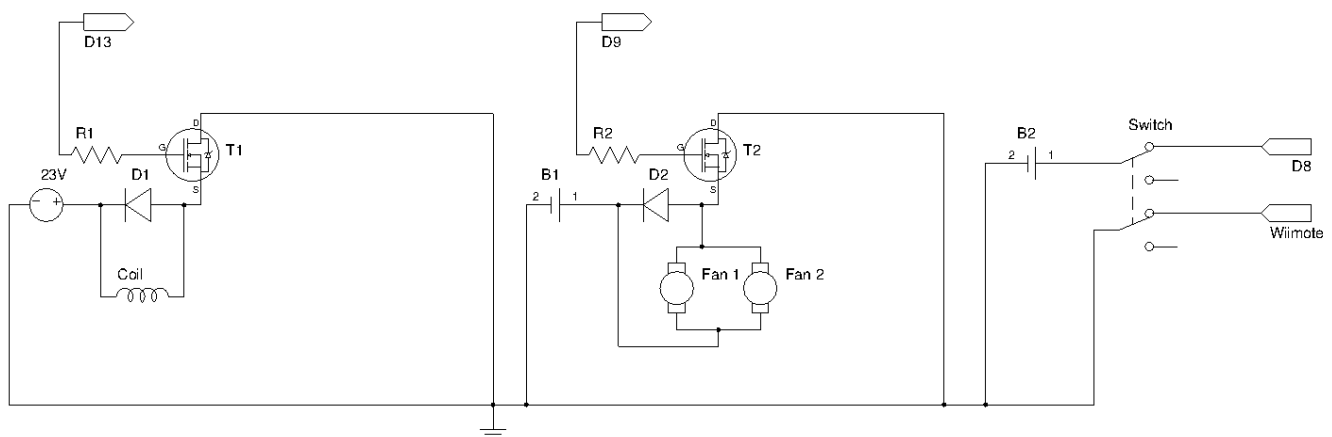

Fig 6. Circuit diagram of controller.

As time went on we did however upgrade the gun and eventually it got more and more stable. First the glue was replaced with screws and nuts around the coil where it got most hot during use, which made it much more stable. The spring installation was changed over time, first with different ways of binding it and later methods to fix its linear motion. In the end the springs moving nodes were fixated and one binding was replaced with a clip device. This setup actually never broke, so it would probably had been a good idea to try this solution earlier.

The last fix of the gun was the installation of fans to cool the coil. The second last day the fan was purely manual and only used to cool the coil while the gun was not in use, at the final day we had a working dual-fan system. Sadly we never got the chance to evaluate this setup as the temperature sensor performed poorly and the transistor circuit which controlled the coil broke, rendering the fans useless.

## EVALUATION

### Heaviness

The final prototype was a compromise of trying to accomplish all of our goals. The recoil was just as strong as we could get it within our time limit and as the available materials allowed it to be. This resulted in a force feedback which was not strong enough to cause surprise or even the physical strain which was the original goal. Still, to our surprise, most testers thought the recoil was satisfying, even when asked the direct question, and only very few thought of it as too weak.

As the final prototype was built on our first prototype being mostly made out of Styrofoam it was not as heavy as we had planned for it to be. It did however end up being satisfyingly heavy and during the exhibition we realized that the weight fitted most ages. The weight was not so big that children could not use the gun and neither was it extremely light for grown-ups. The size of the gun also helped to give the impression of a heavy weapon, something that we had not originally thought much about as we separated the importance of weight and looks.

### Performance

During the exhibition at Nordstan we had the opportunity to let people test the controller. We set up a 32" screen connected to a laptop which ran the game and put our controller in front of it (see figure 7) so that people just could pick it up and start shooting (see figure 8). It turned out that most people at the exhibition liked our idea with the physical recoil and thought it was fun to play. We got some complains of the length of the game, which was too short and had a too low level of difficulty for experienced gamers.

We also had problems with overheating. Even if we had attached a temperature sensor and programmed the Arduino to cut the power to the recoil when it got too hot, the coil got very warm and even melted the glue inside the gun, which

showed that it was not very accurate. To get the temperature down, we installed fans on both sides of the coil.



Fig 7. Exhibition setup.



Fig 8. Spider-kid playing our game with the R.A.G.E. controller.

## The Game Experience

The game we have built became a simple rail first person shooter where the players' mission is to aim and shoot at enemies at the screen before they get too close (for screenshot see figure 9). During the project, our group focused more on the controller than the game itself and therefore it is really just a demo to show that the controller is useful. The game does not have any story or extensive levels that we hoped to be able to create in the beginning of the project, but the core game mechanics are there so it is possible to extend it into a full game with additional levels.



**Fig. 9.** Screenshot from the game.

To replace a traditional game pad with a big, gun shaped controller felt like a good idea for this type of game since it makes more sense in a first person shooter to hold a gun in your hands instead of a small flat plastic device. It seemed like most people enjoyed to play our game at the exhibition. We think that our idea about taking a part of the game out in the real world and make it physical was quite successful.

Integrating the Wiimote as a pointing device was a good idea since the player can turn the gun to the spot on the screen where he or she wants to shoot, without having to press any buttons or keep track of any additional pointing devices. This creates a smooth and natural way of controlling the game.

By the user tests we have performed during the exhibition, most people said that the recoil was the best feature. We think we have managed to create the feeling we were aiming for even if it is not that powerful as we had hoped. The recoil helps to include more of the human senses in the experience of playing a game, than just vision and hearing. One thing that we did not think of when coming up with the idea, was that the recoil not only provides feedback to tell the player that it has been fired, the shaking movement also makes it harder to aim at the enemies in the game when using continuous fire. This provides an extra feature to the gameplay, and makes our gun different from the game controller guns like Nintendo's Zapper, which does not give recoil.

## DISCUSSION

### Visual Design

The looks of the gun (see figure 10) were not as refined as we had originally planned to make them. The visual design was however so appreciated from the very first prototype that it never appeared as an important task to change it. While the actual looks differed from the concepts in that it was simpler, other aspects of the project were more pressing.

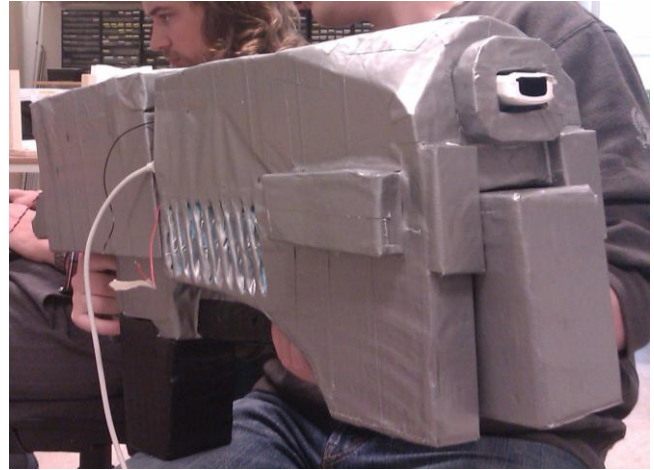

**Fig. 10.** The gun before the exhibition.

The reasoning for the clean design of the gun was to get the concept through. Especially regarding technical devices, details can add to the texture and make the impression interesting as there is much for the eye to discover. It is however easy to add too much detail and thus make it too hard for a user to understand the picture. To tackle this it is important to constantly go back to the whole picture of the design and see if the details add to the visual experience as a whole. In some areas of a design the level of detail might not matter as it's only there to give the impression of some material. Other details might have some attributes that you want the user to see and thus cannot be hidden.



**Fig. 11.** Fictional cooling holes.

Finally there is the aspect of designing fictional details which make sense. While little knobs and blinking diodes can easily be related to technology, and thus sci-fi as is the purpose in this case, adding random details will not add depth to the design of a device. When sketching fictional items it is good to consider the reason for details being there and have some kind of idea of how the device works theoretically. As for the R.A.G.E gun, we chose to put some fictional cooling holes at the front of the gun (see figure 11). While they had no functional purpose and took some time to finish they were much appreciated by testers of the gun.

### Focus on Recoil

Product-wise the recoil system is clearly the most interesting aspect. Firstly this was the single most time consuming feature of the product. (A picture from one of the testing session is shown in figure 12). During the exhibition it caught the most attention and users were mostly interested in how this feature worked. Our project could very well have been narrowed down to focus only on constructing a stable recoil module. Some kind of device which could use the recoiling, such as an arcade gun, would probably have been the best way of showing the module but the gun could have been a minor part of the project. However, as an arcade gun was the original plan for the project we did not realize the importance of the recoil modules quality until late in the development so we would probably not have understood the recoil device as a possible future project had we not done this project.

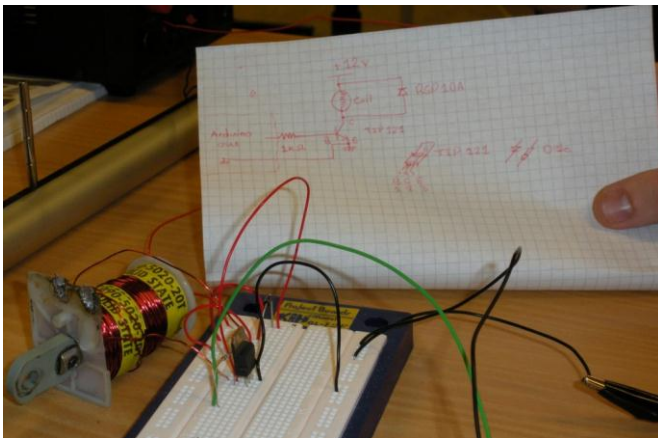

Fig. 12. Experimental recoil circuit.

### User Experience

For the exhibition we never got the time to develop the software side of the game experience as much as we had wanted. For a complete gaming experience the computer game could have been built more around realizing the R.A.G.E. gun's potential. While the gun is constructed to give the user a more physically challenging game experience the computer game which we used for the exhibition could have been more action oriented and immersive, forcing a more physical behavior upon the user. While only one user thought that the game was fast-paced,

and this was an older user which would not typically be in the category of gamers, more testers thought that the demo was too short and would have wanted a more varied gameplay and conclusive ending.

In the later phase of the development we could probably have picked another direction than spending our time trying to realize a finished arcade gun product as much as possible. For instance we could have tested more around the possibilities of alternative interfaces than a single monitor or ways of users holding and interacting with replicas of weapons in games. We never really considered exploring this areas however as we instead went for a prototype of an arcade gun prototype. A reason for this might have been that we got more and more interested in refining the modules of the product as we proceeded in the project, in particular the recoiling module. The idea was that the product in itself was interesting enough in terms of interaction design and we like to believe that this was confirmed with the appreciation we got during the exhibition.

### FUTURE WORK

Due to the time constraints of this project, we did not have time to implement all the features that we came up with. Additional functions and ideas which we think can be suitable for our game and our gun are listed below.

#### Reload Idea

We wanted to implement the feature of reloading "bullets". The idea was to simulate this by having virtual bullets which run out. The user could then remove and reinsert a box representing a bullet clip while getting the feedback of sound effect of reloading bullets. Finally the user would pull a lever on the side of the gun, hearing a reloading sound, representing that the new bullets were prepared to be fired. This would add to the gameplay by making the gun feel more like an actual gun. By making the gun hold its own ammunition count instead of the game doing this the device would be made more portable further enhancing the immersion.

#### Further Development of the Game

For the exhibition, we just implemented a very simple first person rail shooter game to show the interaction between the R.A.G.E. gun and a game. In future work, we would have improved the game so that it had many levels, a story to put the player into some context and also make the product more attractive. A concept and some gameplay mechanics were developed informally but nothing but a few concept pictures were documented.

#### Improved Recoil

The recoil worked pretty well, although we would like it to be a bit stronger. We shouldn't need to do very much to get a better gun. In the last iteration a cooling system with two fans was implemented but could not be properly tested as our temperature sensor performed poorly. While letting the fans be on non-stop the gun seemed to keep cool, but this

could not be thoroughly tested neither as a part of the recoiling module broke before we could document the effects. A future cooling system might not even utilize fans but some kind of liquid cooling or a heat sink. The experience of recoil in our gun can be improved by adding more power to the mechanics which we unfortunately do not have time for now, but at least we have shown for ourselves that the concept holds in the form of a prototype.

Another thing that we would need to work some more on is the spring that holds the rod of the recoil device in place. During the exhibition, the spring pulling back the magnets from the coil occasionally broke. This caused the gun to be out of order from time to time, which was of course not what we desired. As the exhibition went on we made several improvements on this part eventually reaching a rather satisfying setup. Never the less an obvious solution to this problem is to completely remove the spring and replace it with something that is not moving, such as another coil. This could, of course, make the recoil mechanism even warmer as the coil we used generated all of our heat problems. Our heating problems could however probably be solved with a working cooling system.

#### **Common Power Supply**

Another thing that would be good would be to extend the power supply, so it supplies the Arduino, Wiimote and cooling system with power as well. By doing this, we would eliminate the need for extra batteries in the gun. Currently the lack of power in any module but the cooling system will not only cause the module itself to malfunction but also affect the other modules. Except for solving the issue of various power supplies running out at different times we could also look into making the modules more free from each other so that only a limited amount of things stops working when a module is broken.

#### **Computer Interface**

The aiming is probably the gun's weakest part on the software side. Since aiming with a Wiimote usually works just fine the issue could probably be resolved in the software. In order to solve this we would have to study the Wiimote technology more closely and maybe even program our own Wiimote drivers. Another alternative would be to find another pointing technology which does the same thing. This would however not be simple solution as the Wiimote did support us with more than just its pointing feature.

#### **CONCLUSIONS**

One thing that we have learned from this project is that you have to think carefully when using moving parts in a product, as they carry a high risk to break. We saw that with the spring pulling the magnets back from the coil, which we

had to change every now and then because it was not connected in an optimal way and snapped in two pieces. Another example is all the points where parts of the gun were glued or screwed together. The recoil would cause these connections to loosen up over time unless very well fastened.

We also realized that working circuitry should be protected so that nothing touches it. A small bending of a wire or transistor might break the whole thing. To avoid problems with this the product body on which the circuitry is fastened should allow for protection of all solder points. This means that more planning is required when designing an electrical product.

Another problem that we had not taken into account was the friction from the magnets and the coil. This caused the glue holding the coil to melt, which in turn caused the coil to come loose. We made a temporary solution including screws instead of glue, but this construction obviously needs to be overlooked.

The transistor circuit got burned up once (possibly twice) during the exhibition, so we had to go back to the studio and re-solder it. We of course do not want this to happen, as it can only be repaired by someone who understands how the gun works. As a counter measure to this and other heating problems we only used one of the power sources instead of connecting them serially. By doing this the recoil got weaker, but we felt that it was a price worth paying for not having to re-solder the circuit again.

The overall reaction to the gun was that it was a fun and interesting product, which of course felt very positive considering the problems that occurred during the exhibition. By creating an external controller with advanced force feedback, the user gets the feeling that he/she is more a part of the game, creating a greater user experience. One thing that was fun to see was that both adults and children wanted to try out the gun. Sometimes it could be a little hard for the children to aim, as they were quite a bit shorter than the grown-ups, but most of the time we could solve it by placing them on a high chair.

#### **ACKNOWLEDGMENTS**

We would like to thank Farshid Jafari Harandi, Amir Sabbagh Pour, Alejandro Valenzuela Roca and Simon Morris for their help during the development of the game controller.

#### **REFERENCES**

1. Salen, K & Zimmerman, E. *Rules of Play – Game Design Fundamentals*. (The MIT Press 2004).
2. A. Norman, D. *Emotional Design – Why we love (or hate) everyday things*. (Basic Books 2004).